

NS12-7.5

12V 7.5Ah



Introduction

E-GUARD NS UPS (4.5Ah-28Ah) series is designed for standby use with a 5-year design life in float service. This series of battery features high consistency, excellent performance and reliable standby service life. It is widely applied in UPS/EPS, medical equipment, emergency light and security system.

Battery Features

- Low self-discharge
- Fully tank formed plates
- Low impurity electrolyte
- Spill proof / leak proof
- Multi-position usage
- ABS case and cover VO upon request
- Very high purity lead

Electrical Specification

Design floating Life @ 25°C (77°F)	5 years
Nominal Capacity @ 25°C / 77°F	
20 hour rate 0.38A to 1.75Vpc	7.6 Ah
10 hour rate 0.71A to 1.75Vpc	7.1 Ah
Internal Resistance	
(Fully charged battery @ 25°C / 77°F)	22 mΩ
Max. Discharge Current @ 25°C / 77°F	105 A (5S)
Charge Methods: Constant voltage charge @ 25°C / 77°F	
Cycle Use	14.7 ~ 14.9V
Max. Current	1.7 A
Standby Use	13.6 - 13.8V
Operating Temperature Range	-30 ~ 50°C
<i>Notes: battery voltage must be adjusted according to temperature. Please refer to our recommendation.</i>	
Self-Discharge	
3% of capacity declined per month @ 25°C (77°F).	

Battery Picture & Terminal Layout

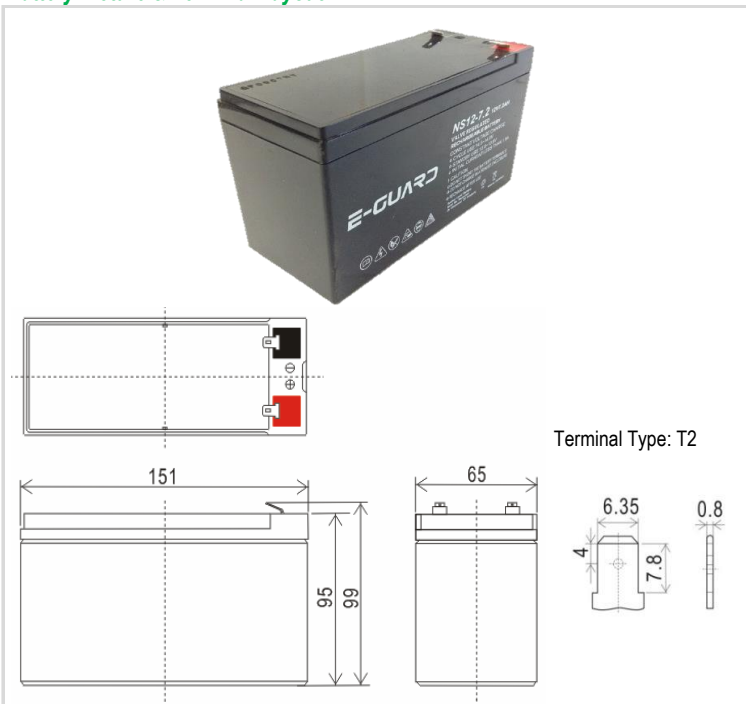

Dimension & Weight

Length	Dimension (± 2mm)			Total Height	Weight (± 2%)
	Width	Height			
151 mm	65 mm	95 mm	99 mm	2.22 kg	
5.9 inch	2.6 inch	3.7 inch	3.9 inch	4.9 lbs	

Typical Applications

- UPS & EPS
- Security Power Supply
- Power Utility
- Electrical Toys

Certificates



Constant Current Discharge (Amperes @ 25°C / 77°F)

V/cell	10min	15min	20min	25min	30min	35min	40min	45min	50min	55min	1hr	2hr	3hr	4hr	5hr	10hr	20hr
1.60	17.06	13.02	11.13	9.23	7.79	6.79	6.24	5.68	5.18	4.73	4.33	2.34	1.82	1.56	1.35	0.74	0.38
1.65	16.34	12.47	10.67	8.87	7.51	6.54	6.02	5.50	5.03	4.61	4.24	2.29	1.78	1.53	1.33	0.73	0.38
1.70	15.62	11.92	10.21	8.49	7.23	6.29	5.80	5.31	4.87	4.48	4.14	2.24	1.74	1.50	1.30	0.72	0.38
1.75	14.90	11.37	9.75	8.13	6.96	6.05	5.59	5.13	4.72	4.36	4.05	2.18	1.68	1.46	1.28	0.71	0.38
1.80	14.18	10.82	9.30	7.78	6.71	5.83	5.39	4.96	4.58	4.24	3.96	2.13	1.63	1.42	1.26	0.69	0.36

Constant Power Discharge (Watts/cell @ 25°C / 77°F)

V/cell	10min	15min	20min	25min	30min	35min	40min	45min	50min	55min	1hr	2hr	3hr	4hr	5hr	10hr	20hr
1.60	32.68	24.94	21.22	17.49	14.74	12.84	11.92	11.00	10.29	9.47	8.75	4.80	3.67	3.13	2.46	1.50	0.81
1.65	31.36	23.94	20.36	16.78	14.19	12.32	11.43	10.54	9.85	9.07	8.38	4.58	3.57	3.06	2.42	1.48	0.79
1.70	30.03	22.93	19.53	16.14	13.73	11.87	11.00	10.12	9.45	8.68	8.00	4.36	3.47	2.99	2.37	1.47	0.78
1.75	28.95	22.10	18.80	15.50	13.18	11.35	10.51	9.66	9.02	8.27	7.63	4.14	3.37	2.92	2.33	1.45	0.78
1.80	27.63	21.09	17.97	14.86	12.72	10.92	10.11	9.30	8.68	7.97	7.35	3.99	3.25	2.83	2.27	1.43	0.73

Subject to revision without notice. Please contact our sales representatives for latest version.

Web: www.enervision.co.za | Email: sales01@enervision.co.za | Telephone: 0861 111 270

VERSION:20200519



NS12-7.5

12V 7.5Ah

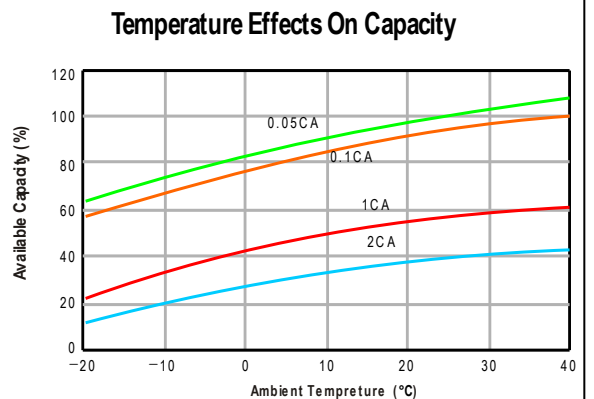
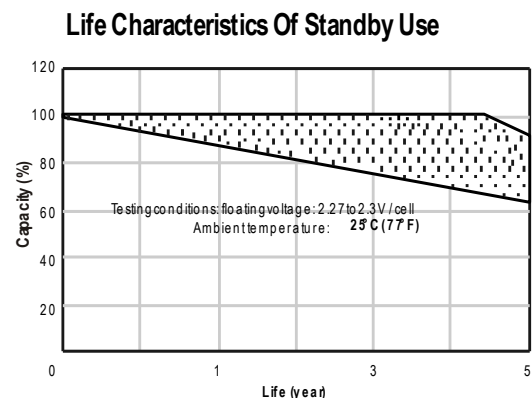
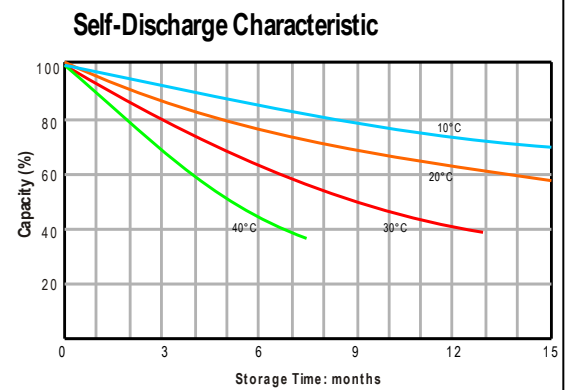
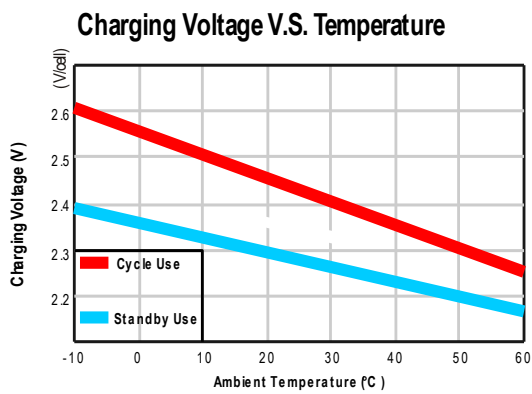
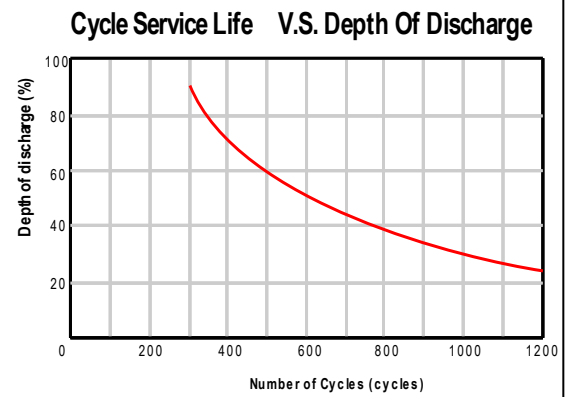
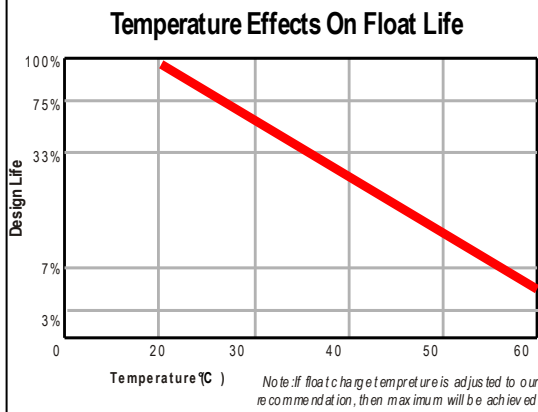
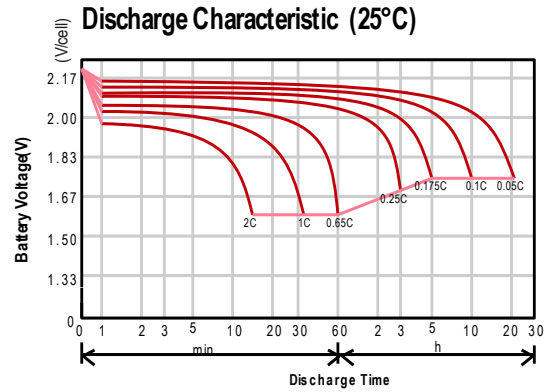
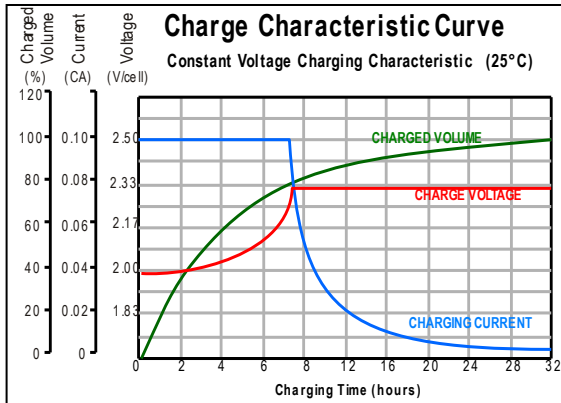

Subject to revision without notice. Please contact our sales representatives for latest version.

Web: www.enervision.co.za | Email: sales01@enervision.co.za | Telephone: 0861 111 270

VERSION:20200519