

NM12-100L

12V 100Ah



Introduction

E-GUARD NML (Long life) Series is designed for solar and renewable energy systems. GEL electrolyte and AGM separator are applied in this series which features long service life. It is widely used in solar and wind power system, UPS and power utility.

Battery Features

- Increase durability and deep cycle ability for heavy demand applications
- Low self-discharge
- Fully tank formed plates
- Low impurity electrolyte
- Spill proof / leak proof
- Multi-position usage
- ABS case and cover VO upon request
- Very high purity lead

Electrical Specification

| | |
|--|--------------|
| Design floating Life @ 20°C (68°F) | 10 years |
| Nominal Capacity @ 25°C / 77°F | |
| 20 hour rate 5.41A to 1.75Vpc | 108.2 Ah |
| 10 hour rate 10.54A to 1.75Vpc | 105.4 Ah |
| Internal Resistance | |
| (Fully charged battery @ 25°C / 77°F) | 5mΩ |
| Max. Discharge Current @ 25°C / 77°F | 1000 A (5S) |
| Charge Methods: Constant voltage charge @ 25°C / 77°F | |
| Cycle Use | 14.7 ~ 14.9V |
| Max. Current | 27 A |
| Standby Use | 13.6 - 13.8V |
| Operating Temperature Range | -30 ~ 50°C |
| <i>Notes: battery voltage must be adjusted according to temperature. Please refer to our recommendation.</i> | |
| Self-Discharge | |
| <3% of capacity declined per month @ 25°C (77°F). | |

Battery Picture & Terminal Layout

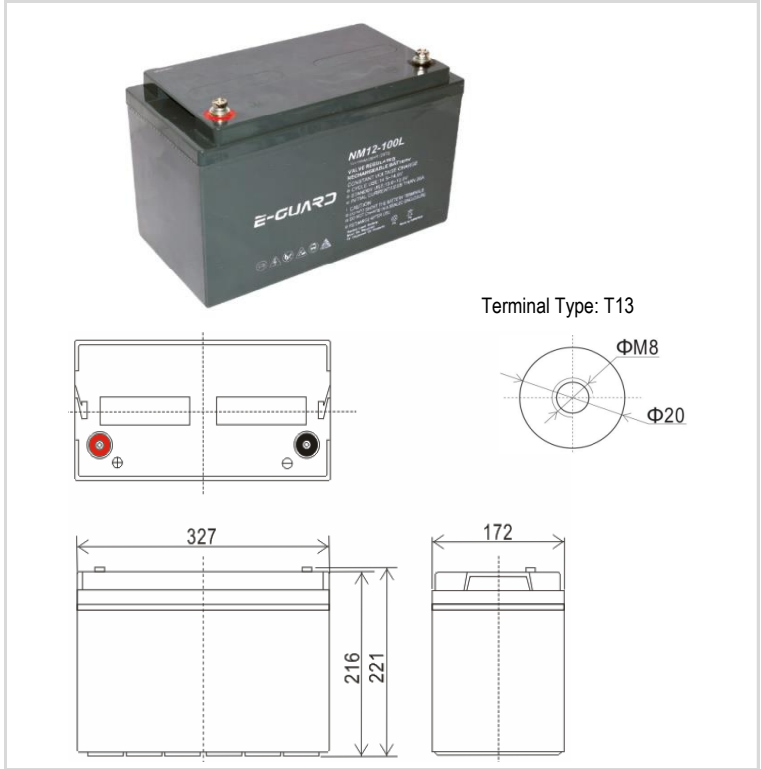

Dimension & Weight

| Length | Dimension (± 2mm) | | | Total Height | Weight (± 2%) |
|-----------|-------------------|----------|----------|--------------|---------------|
| | Width | Height | | | |
| 327 mm | 172 mm | 216 mm | 221 mm | 30.5 kg | |
| 12.9 inch | 6.8 inch | 8.5 inch | 8.7 inch | 67.2 lbs | |

Typical Applications

- Solar/Wind Energy System
- Power Utility
- UPS/EPS

Certificates



Constant Current Discharge (Amperes @ 25°C / 77°F)

| V/cell | 10min | 15min | 20min | 25min | 30min | 35min | 40min | 45min | 50min | 55min | 1hr | 2hr | 3hr | 4hr | 5hr | 10hr | 20hr |
|--------|-------|-------|-------|-------|-------|-------|-------|-------|-------|-------|------|-------|-------|-------|-------|-------|------|
| 1.60 | 247.8 | 189.2 | 163.4 | 137.7 | 116.5 | 106.5 | 99.3 | 92.7 | 86.7 | 80.7 | 77.2 | 41.85 | 29.77 | 24.73 | 20.22 | 10.80 | 5.46 |
| 1.65 | 235.3 | 179.6 | 156.0 | 132.4 | 113.4 | 103.7 | 96.8 | 90.6 | 84.9 | 79.3 | 76.1 | 41.04 | 29.20 | 24.21 | 19.75 | 10.75 | 5.46 |
| 1.70 | 225.6 | 172.2 | 149.9 | 127.5 | 109.8 | 100.2 | 93.7 | 87.7 | 82.3 | 77.0 | 74.0 | 39.65 | 28.53 | 23.64 | 19.29 | 10.65 | 5.46 |
| 1.75 | 215.2 | 164.3 | 143.2 | 122.1 | 105.6 | 96.4 | 90.3 | 84.8 | 79.8 | 75.0 | 72.5 | 38.55 | 27.91 | 23.12 | 18.87 | 10.54 | 5.41 |
| 1.80 | 204.1 | 155.8 | 136.1 | 116.5 | 101.4 | 92.6 | 86.8 | 81.6 | 77.0 | 72.5 | 70.4 | 37.17 | 27.23 | 22.55 | 18.40 | 10.27 | 5.35 |

Constant Power Discharge (Watts/cell @ 25°C / 77°F)

| V/cell | 10min | 15min | 20min | 25min | 30min | 35min | 40min | 45min | 50min | 55min | 1hr | 2hr | 3hr | 4hr | 5hr | 10hr | 20hr |
|--------|-------|-------|-------|-------|-------|-------|-------|-------|-------|-------|-------|-------|-------|-------|-------|-------|-------|
| 1.60 | 430.4 | 328.5 | 289.1 | 249.7 | 217.7 | 199.4 | 185.2 | 172.2 | 160.1 | 148.5 | 140.7 | 77.36 | 56.29 | 46.71 | 38.47 | 21.55 | 11.37 |
| 1.65 | 415.1 | 316.9 | 279.5 | 242.0 | 212.0 | 194.1 | 180.5 | 168.0 | 156.4 | 145.3 | 138.1 | 75.79 | 55.77 | 46.19 | 37.95 | 21.35 | 11.37 |
| 1.70 | 399.2 | 304.7 | 269.1 | 233.4 | 205.2 | 188.0 | 175.0 | 163.2 | 152.3 | 142.0 | 135.5 | 73.96 | 54.74 | 45.39 | 37.38 | 20.93 | 11.22 |
| 1.75 | 381.8 | 291.5 | 257.8 | 224.2 | 197.9 | 181.3 | 169.1 | 157.9 | 147.7 | 138.2 | 132.3 | 71.61 | 53.18 | 44.27 | 36.70 | 20.77 | 11.01 |
| 1.80 | 363.1 | 277.1 | 245.7 | 214.2 | 190.1 | 174.1 | 162.5 | 152.0 | 142.6 | 133.8 | 128.7 | 69.07 | 51.78 | 43.16 | 35.87 | 20.57 | 10.91 |

Subject to revision without notice. Please contact our sales representatives for latest version.

Web: www.enervision.co.za | Email: sales01@enervision.co.za | Telephone: 0861 111 270

VERSION:20200519



NM12-100L

12V 100Ah

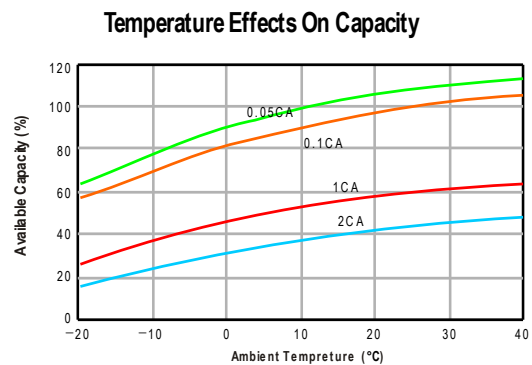
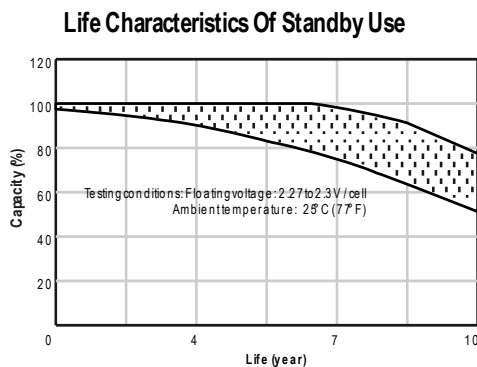
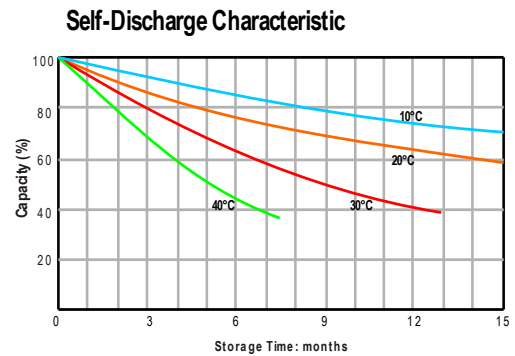
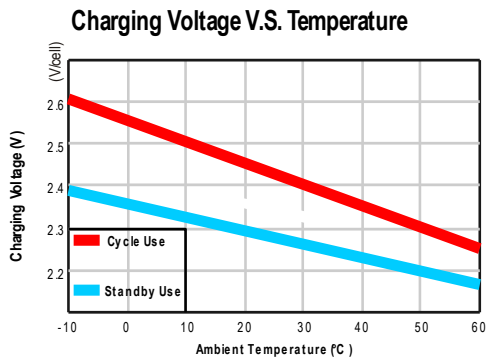
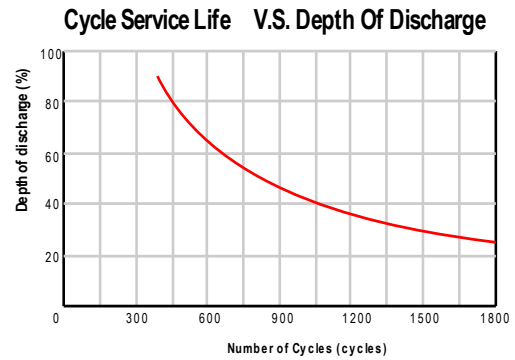
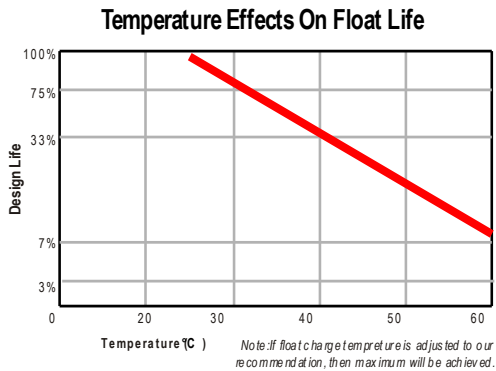
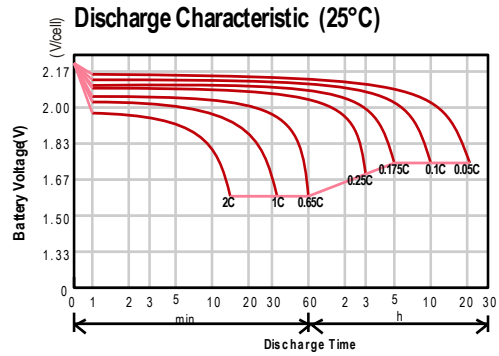
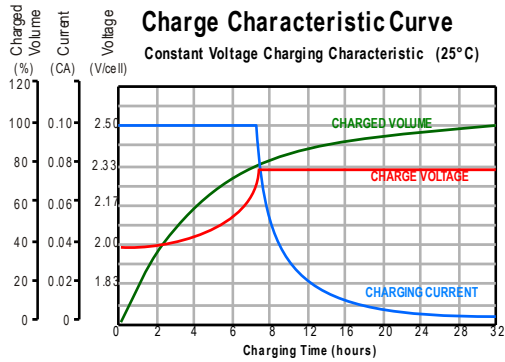

Subject to revision without notice. Please contact our sales representatives for latest version.

Web: www.enervision.co.za | Email: sales01@enervision.co.za | Telephone: 0861 111 270

VERSION:20200519